



	Fresh Water	Pool Water	Sea Water	220-240 V	400 V	110-120 V	50 Hz	60 Hz	12 V AC	24 V DC	DMX	DMX/RDM	Plug and Spray
Varionaut 150/DMX/02	✓	✓	✓	✓	✓	✓	✓	✓	✓	✓	✓	✓	✓

VARIONAUT 150/DMX/02

The 230 Volt – alternating current – version of the Varionaut manages to connect to a Comet 10-12 T shoot to height of up to 3.50 m. Any single pump can be individually regulated and controlled by the DMX connection. With this dynamic water effects can be created easily.

The Varionaut 150/DMX/02 (50343) comes with a power connection cable of 10 m and a DMX cable of 1 m. With these special connection boxes, hand wiring is no longer necessary. This IP 68 waterproof, patented connection system makes the installation safer, easier and faster. Spotlights and other consumer loads (eg. LED

spotlights) can easily be connected to the DMX of the pump. The Varionaut 150/DMX/02 has a power consumption of 130 W and a power supply of AC 220-240V 50/60Hz.

Product characteristics at a glance

- 230V/AC fountain pump with alternating current for the application indoor and outdoor
- Suitable for wet or dry installation
- Power consumption of max. 130 W
- 10m power cable with plug and 1m DMX cable with DMX box (50343)
- IP 68 rated
- RDM-DMX capable



Varionaut 150/DMX/02

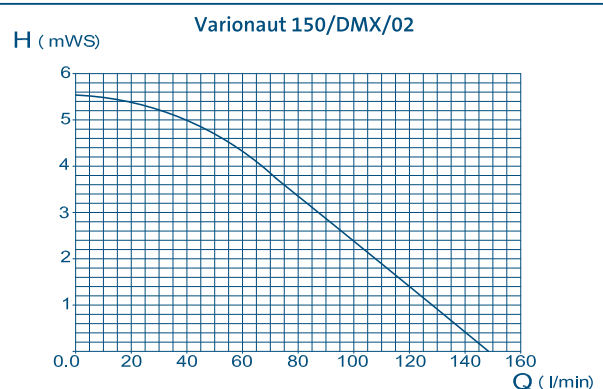

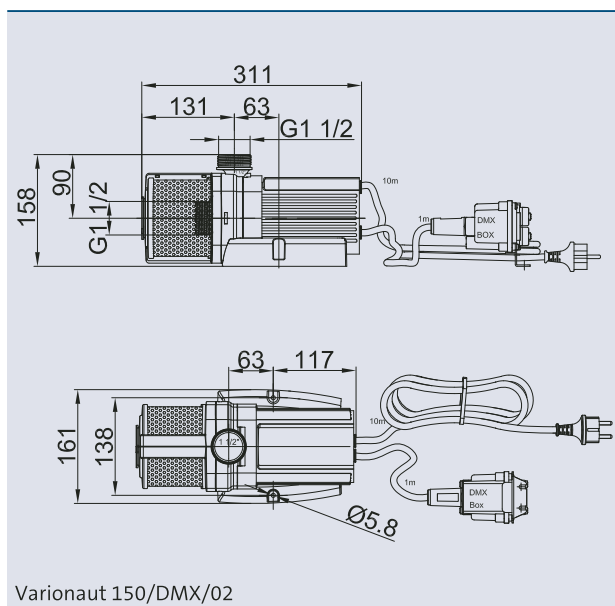

Varionaut 150/DMX/02

To operate the Varionaut 150 or Varionaut 2/A an OASE Easy Control or OASE WECS is required (not included).

Accessories (must be ordered separately)

Comet 10-12 T (see page 44)	50968
Reducing Sleeve 15x10 (see page 245)	51032
Connecting cable DMX/01 (see page 162)	Order no.
Connecting cable DMX/1.0 m/01	12368
Connecting cable DMX/3.0 m/01	12369
Connecting cable DMX/5.0 m/01	12371
Connecting cable DMX/10.0 m/01	12372
Connecting cable DMX/20.0 m/01	12373
End Resistant for Bus-System DMX/01	12007
WECS II 512 / DMX/02 (see page 174)	56491
WECS II 1024 / DMX/02 (see page 174)	56492
WECS II 2048 / DMX/02 (see page 180)	56507

	Varionaut 150/DMX/02		Varionaut 150/DMX/02	
Motor Type/ Electronic	230 V EC-Motor, DMX controlled (DMX-RDM enabled)		230 V EC-Motor, DMX controlled (DMX-RDM enabled)	
Hmax	[m]	5.60	[ft]	18
Qmax	[l/min]	150	[gph]	2400
Power max.	[W]	130	[W]	130
Nominal current	[A]	1.37	[A]	1.37
Dynamic behaviour speed: (time to reach full fountain height from 0 – 100 %) with comet 5-8	[s]	1	[s]	1
Qmin (offset mode – DMX 0)	[l/min]	24	[gph]	380.4
Max. Powering up / min. Off time	[s]	1 x per minute / 10	[s]	1 x per minute / 10 s
Nominal voltage	[V/Hz]	220-240, 50/60	[V/Hz]	220-240, 50/60
Immersion depth max.	[m]	4	[ft]	13.10
Protection class		IP 68		IP 68
Dimensions incl. filter (LxWxH)	[mm]	311 x 161 x 158	[inch]	12.20 x 6.30 x 6.20
Suction side connection	[inch]	Thread G 1 ½ (external thread)	[inch]	Thread G 1 ½ (external thread)
Pressure side connection	[inch]	Thread G 1 ½ (external thread)	[inch]	Thread G 1 ½ (external thread)
Weight	[kg]	4.90	[lb]	11
Filter housing		Plastic / stainless steel 1.4301 (AISI 304)		Stainless steel / plastic
Input DMX		1 m BUS cable with DMX box		3.28 ft. BUS cable with DMX box
Input power		10 m power cable with plug		20 ft power cable without plug
Number of DMX channels		2 channels (control channel, speed channel)		2 channels (control channel, speed channel)
Environmental conditions: submersible application	[°C]	Water temperature: min. 4 to max. 35	[°C]	Water temperature: min. 4 to max. 35
Environmental conditions: dry application	[°C]	Ambient temperature: max. 30 with natural convection, max. 40 with forced convection, no direct sun exposure permitted	[°C]	Ambient temperature: max. 30°C with natural convection, max. 40 with forced convection, no direct sun exposure permitted
Order no.		50343		57690