



G2 Heat Exchanger Installation & Operating Manual



CONTENTS

1. PRODUCT OVERVIEW	3
1.1 Specification	3
1.2 Dimensions.....	4
2. GENERAL INSTALLATION INSTRUCTION	4
2.1 Mounting instruction	4
2.2 Flow direction	5
3. WATER QUALITY.....	7
4. WARRANTY	7

INTRODUCTION

Thank you for purchasing the Elecro G2 Heat Exchanger, manufactured in the UK to exacting standards, using the highest quality materials, to ensure exceptional performance and reliability.

To ensure years of trouble-free service, please **read and follow** these instructions for proper installation, maintenance and use.

WARNING: Failure to install the unit correctly may result in the warranty being void.

Please retain this manual for future reference.

1. PRODUCT OVERVIEW

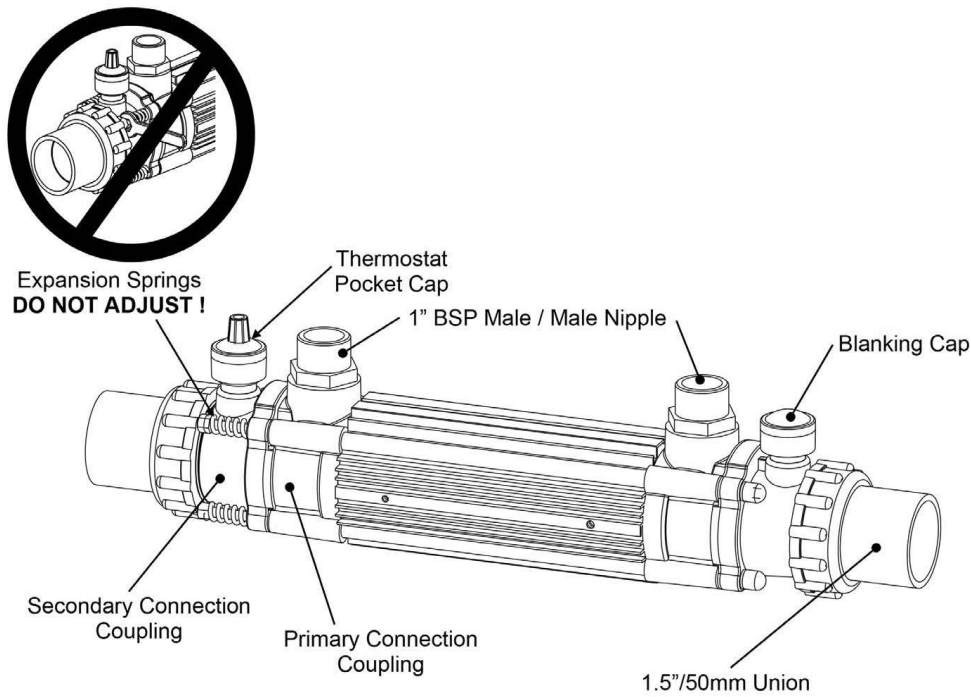

Fig.1

1.1 Specification

Standard Output	Primary Flow [m³/h]	Primary Head Loss (kpa)	Secondary Flow [m³/h]	Secondary Head Loss (kpa)	ΔT 15°C [kW]	ΔT 20°C [kW]	ΔT 30°C [kW]	ΔT 40°C [kW]	ΔT 50°C [kW]	ΔT 60°C [kW]	ΔT 70°C [kW]
30-kW	1.1	6.1	10	5.0	9	11	16	20	26	30	33
30-kW	1.3	6.8	10	5.0	10	13	18	23	31	34	39
30-kW	1.3	6.8	14	7.0	11	15	20	26	34	41	46
49-kW	1.6	7.7	16	9.2	13	18	25	43	41	50	56
49-kW	1.8	8.3	16	9.2	15	20	28	38	45	55	62
49-kW	2.2	9.6	17	9.8	16	22	33	44	52	64	73
85-kW	2.4	11.3	17	10.6	22	28	40	53	64	75	81
85-kW	2.7	12.9	17	10.6	26	32	46	60	73	82	89
85-kW	3.2	14.7	17	10.6	28	34	49	64	77	90	102
122-kW	3.8	18.3	19	12.6	33	43	68	75	93	108	120
122-kW	4.2	20.0	19	12.6	36	48	70	89	108	126	143
122-kW	4.6	21.1	19	12.6	38	73	73	95	116	137	156

- ΔT = Temperature difference between Primary and Secondary
- To calculate BTU, multiply kW x 3412 = BTU Output

Note: Maximum primary operating temperature is 95°C

1.2 Dimensions

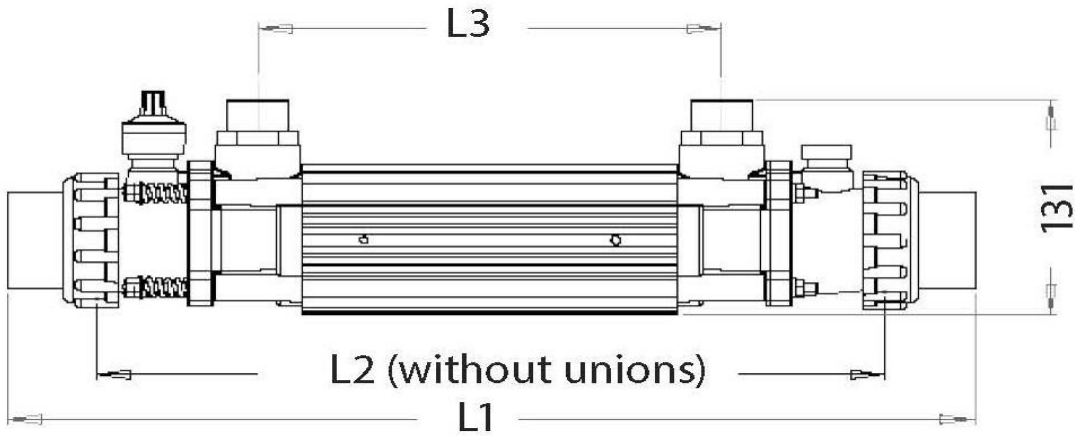

Fig. 2

	L1(mm)	L2(mm)	L3(mm)
30 – kW	540	426	247
49 – kW	710	596	417
85 – kW	840	726	547
122 - kW	1000	886	707

2. GENERAL INSTALLATION INSTRUCTION

2.1 Mounting instruction

The Heat Exchanger can be either installed horizontally or vertically allowing enough space for the pipe connections.

Caution: *If the Heat Exchanger is unused during the winter months, it **must be** drained to prevent frost damage. Water **must not be** allowed to freeze in the Heat Exchanger, as this will cause severe damage.*

The Heat Exchanger should be installed at a low point in the filtration system. It should be positioned downstream of (after) the filter and upstream of (before) any dosing or other water treatment plan. (see Fig. 3).

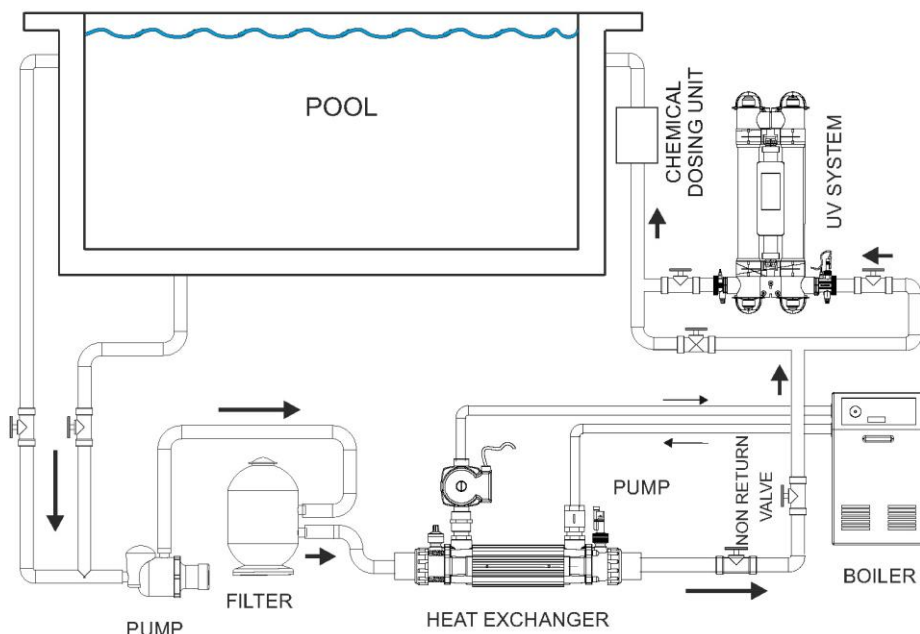

Fig. 3

Horizontal wall mounting:

1. Fix the supplied wall bracket as shown securing with two screws (fixings not supplied)

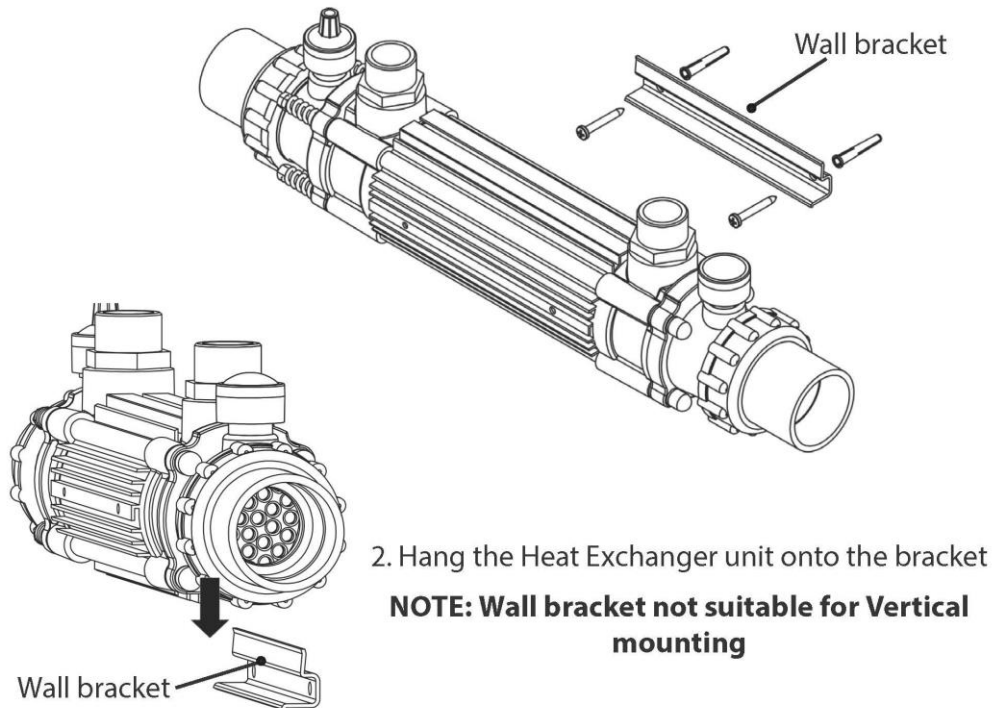

Fig. 4

2.2 Flow direction

Your G2 Heat Exchanger should be connected to the two independent water circuits as follows:

1. Connection to Water Filtration Circuit (Secondary)

The Heat Exchanger should be plumbed in-line, after the filtration pump and filter and before any water treatment equipment. It must be fed with clean water. Weed/debris should not be allowed to enter the Heat Exchanger. Universal 1.5" / 50mm ABS unions for connection to rigid PVC or ABS pipe are included (stepped internal diameter to accommodate both sizes). The Heat Exchanger should be installed as close as possible to the boiler/heat source to minimise heat loss.

To assist with correct air purging and to ensure that the Heat Exchanger remains full of water during operation, it should be installed at the lowest point in the filtration circuit.

If the Heat Exchanger is installed in a vertical plain, it is essential that the pool/pond water (secondary circuit) enters low and exits high.

2. Connection to Heating or Cooling Circuit (Primary)

The Heat Exchanger should be connected directly to the primary circuit i.e. boiler/chiller via the provided 1" BSP male brass connectors.

NOTE: *The circulation pump of the primary circuit should be controlled by a thermostat, which should be connected via the filtration pump to allow heating only when the filtration pump is running.*

Air bleed valves should be installed at the high points of the primary circuit. To ensure correct temperature detection, it is essential that the thermostat / thermistor is positioned at the pool / pond water inlet of the Heat Exchanger. The thermostat pocket and blanking cap use a common port and can thus be swapped as required.

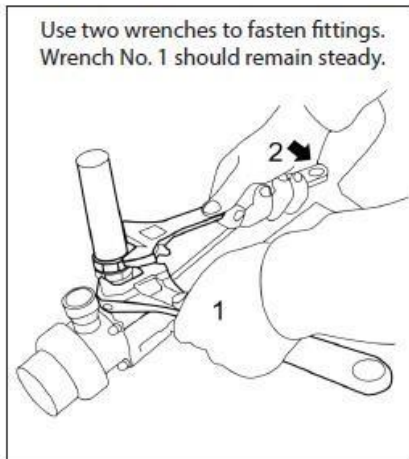

Care should be taken not to over tighten any connections, as this could result in damage to the Heat Exchanger.

Only use the supplied brass connectors as other uncertified connectors may leak or cause damage to the unit.

The primary and secondary circuits should be installed so water flows are counter current i.e. the water from the primary circuit should flow in the opposite direction to the water in the secondary circuit.

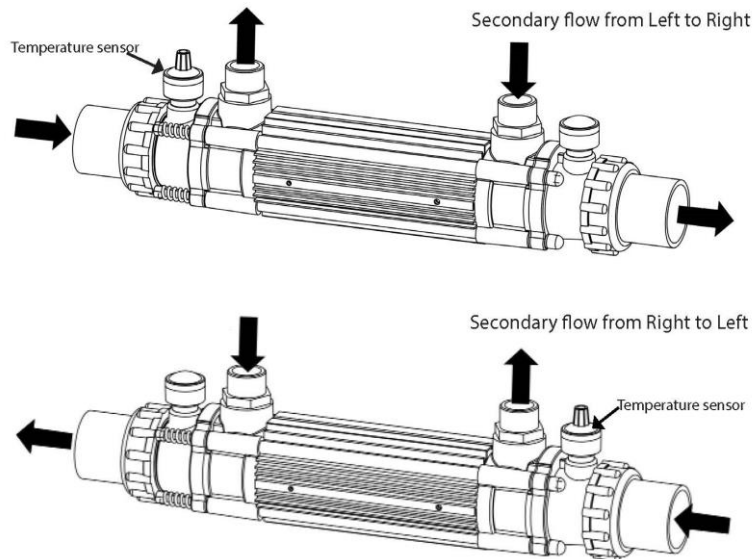

CAUTION: If the Heat Exchanger is not used during the winter months, it must be drained to prevent frost damage.

NOTE: For Winterising / maintenance, it is recommended that the Heat Exchanger is installed with isolation valves on both water input and output sides of the primary and secondary circuits. This will allow the water to be shut off on both sides and aid removal from the system, when required.

3. WATER QUALITY

To prevent damage to your Heat Exchanger, the water quality **MUST** be within the following limits:

- PH: 6.8 – 8.0
- Total Alkalinity (TA): 80 – 140 ppm (parts per million)
- Chloride Content MAX: 150 mg/litre
- Free Chlorine: 2.0 mg/litre
- Total Bromine: Max 4.5 mg/litre
- Total Dissolved Solids (TDS)/Calcium hardness: 200 – 1,000 ppm

4. WARRANTY

This product is guaranteed from the date of purchase against faulty workmanship and materials for:

- **two years within Europe**
- **one year outside of Europe**
- The manufacturer will replace or repair, at its discretion, any faulty units or components returned to the Company for inspection.
- Proof of purchase may be required.
- The manufacturer will not be liable in cases of incorrect installation of the heater, inappropriate use or neglect of the heater.
- Any damages occurred due to shipping must be reported within 48 hours of receipt of the product. Any claims after this time will be considered as misuse or abuse of the product and will not be covered by the warranty.
- Any glass parts, seals and water connections are considered as consumables and are not covered by the warranty.



11 Gunnels Wood Park, Stevenage, Herts SG1 2BH
Sales@elecro.co.uk www.elecro.co.uk +44 (0) 1438 749474

© Copyright V01.2019